

# ORWAK HORIZONTAL 800 AT

Our fully automated horizontal 80 ton baler meets the challenges by centralized waste handling in many businesses and organizations where huge volumes of recyclable paper-based and plastic wrapping are produced. We offer well-proven technology for special demands! The automatic tying and the continuous baling enable multi-shift operation.



**AUTOMATIC  
SOLUTION**



**CAPACITY  
CARDBOARD**



**BALE WEIGHT  
CARDBOARD**



## ORWAK BENEFITS



### **MORE PRODUCTIVE USE OF TIME**

Less time spent on waste handling, more time for your core activities!

### **MORE SPACE & ORDER**

Our balers rapidly minimize the space the waste takes up, keeping aisles free and tidy.

### **LESS COSTS, MORE VALUE**

More compaction = less waste volume to transport. Fewer transports required results in lower transportation costs and reduced CO<sub>2</sub> emissions. Sorting at source yields a higher quality of waste material for recycling.

## WHY ORWAK HORIZONTAL?

- Effective large-scale waste handling
- Improved internal and external logistics
- Safe and comfortable working environment
- Excellent control over the throughput
- Increased income when delivering high-quality bales directly to the recycling industry.

**ORWAK**  
PART OF **SULO** GROUP

# ORWAK HORIZONTAL 800 AT

Smart fully automated solution

## CONTINUOUS FEEDING AND OUTPUT

A completely automated waste management solution designed for continuous infeed, automatic horizontal or vertical strapping system with adjustable wire links, which enables you to yield optimal output.

## EQUIPPED WITH A PROGRESSIVE CUTTING SYSTEM

for extra effective compaction.



## OPTIMAL FEATURES

- Well proven technology
- Auto start (photocell) as standard
- High speed: fast throughput
- Adjustable bale length
- Bale counter
- Oil cooler
- Vertical or horizontal automatic tying



## HORIZONTAL 800 AT IS OPTIMIZED FOR:

### PAPER

- Paper sacks
- Cardboard

### PLASTIC

- Shrink film
- PET/PEHD

### METAL

- Food cans
- Pain cans

### WOOD

- Crates

## A VARIETY OF INFEEED OPTIONS

To fit the conditions in your environment, our horizontal balers offer a wide choice of infeed systems: manual, by bin, air-transport and conveyor belt. Our balers can also easily be equipped with shredders, bottle presses, rufflers, strippers and different types of hoppers.

## OPTIONS

- Horizontal tying
- Bin lifter
- Conveyor belt
- Cooling and heating systems
- Stamper

*More special options on demand*

## DIMENSIONS & SPECIFICATIONS

### TECHNICAL SPECIFICATIONS

MACHINE DIMENSIONS (LXWXH) EXCL BALE EXIT	FEED OPENING	INFEEED CAPACITY	PRESS FORCE	MOTOR	SURFACE PRESSURE	CYCLES PER MINUTE	CHANNEL SECTION	OIL TANK CAPACITY
8515x2150x3450 mm	1550x1000 mm	1.24 m <sup>3</sup>	80 ton	55 kW/75 Hp	10 kg/cm <sup>2</sup>	5	1000x800 mm	1000 L

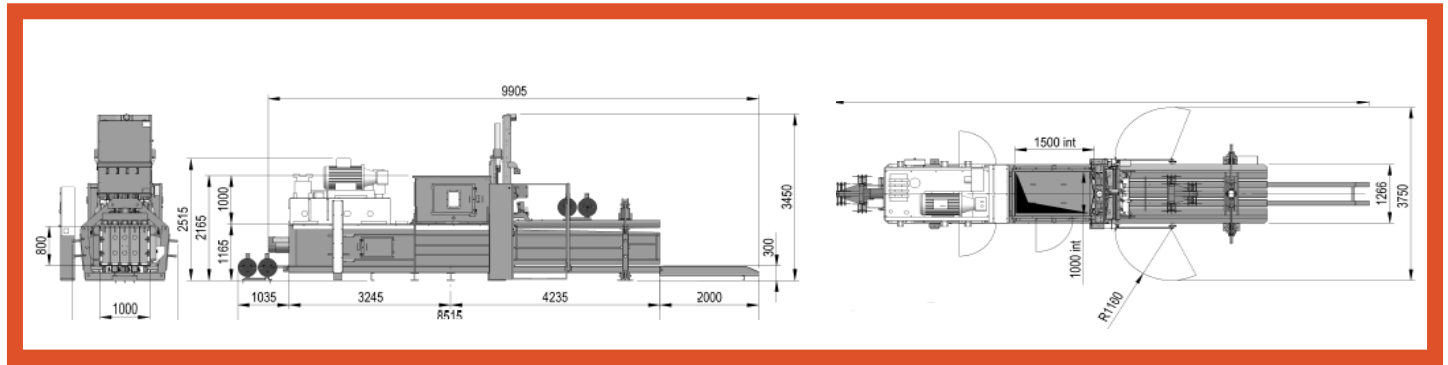

### TECHNICAL SPECIFICATIONS

TOTAL MACHINE WEIGHT	PRODUCTION RATE WITH LOAD	PRODUCTION ACCORDING TO DENSITY	AUTOMATIC BINDING	BALE SIZE (ADJUSTABLE LENGTH)	BALE WEIGHT CARDBOARD <i>DEPENDS ON BALE LENGTH</i>
13000 kg	225 m <sup>3</sup> /h	8-13 t/h	4 wires Ø 3.2	1000x800x800-2200 mm	400-800 kg

*We reserve the right to make changes to specifications without prior notice. Bale weights are dependent upon material type.*

## ORWAK AB

Svetsaregatan 4  
S-576 33 Sävsjö  
SWEDEN  
Tel: +46-(0)382-15700  
info@orwak.com

**ORWAK.COM**

